

23-24-25 september

**1th Benelux Steel
CHALLENGE
Team/M1-B**

**6- Stages
Min-R : 150**

Food and Drinks available
on the "Range"



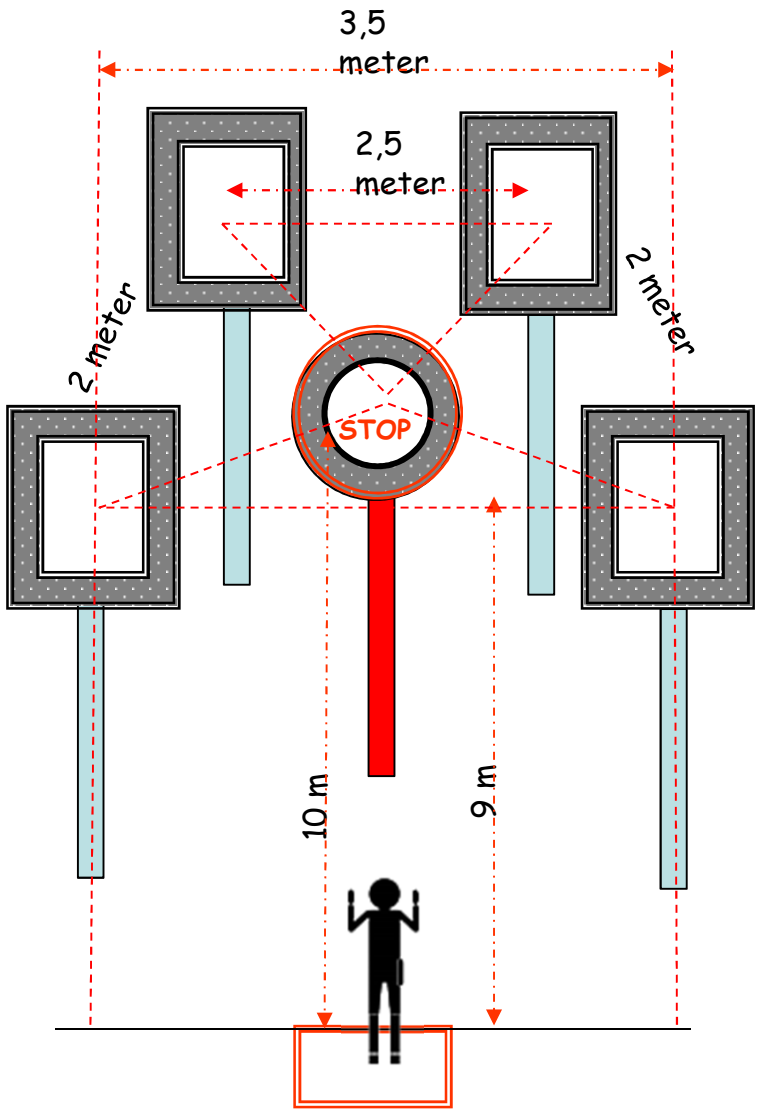

4 x 200/300 Pleets
1 x 300 Stoppleet

Stage: 1
Speed

Stage: 1 & 2

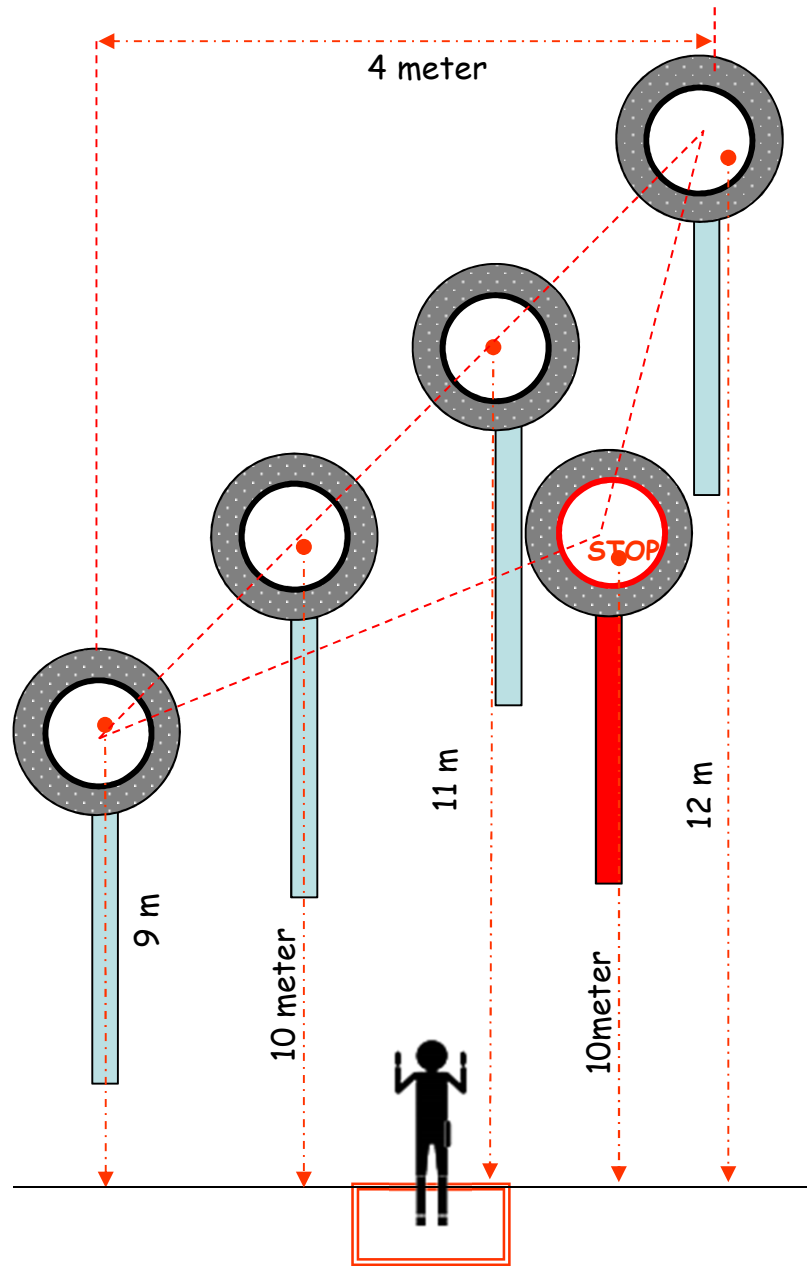

Stage: 2
Limits

4 x 300 Pleets
1 x 200/300 Stoppleet

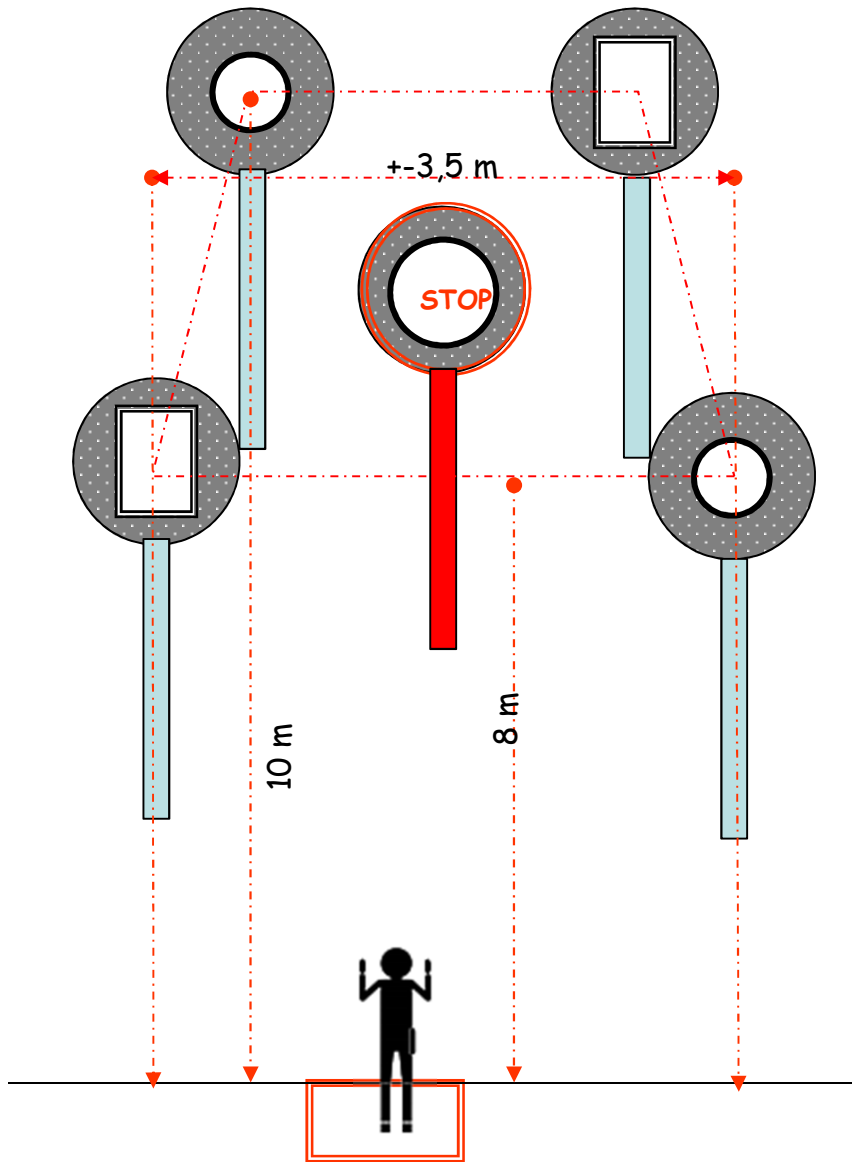

- 2 x Pleets 250
- 2 x Pleets 200/300
- 1 x Stoppleet

Stage: 3
Think and Shoot

Stage: 3 & 4

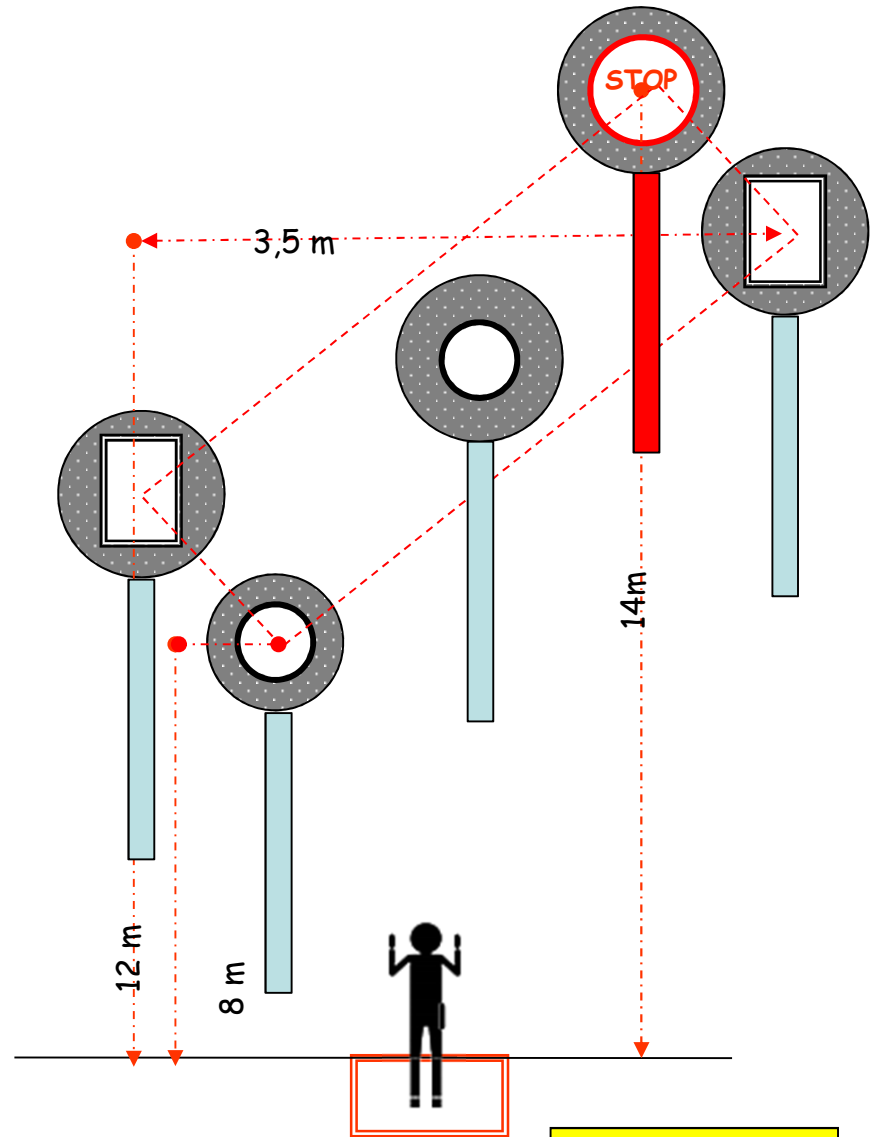

- 1 x Pleet 200
- 1 x Pleet 250
- 2 x Pleet 200/300
- 1 x Stoppleet 200

Stage: 4
Already in line

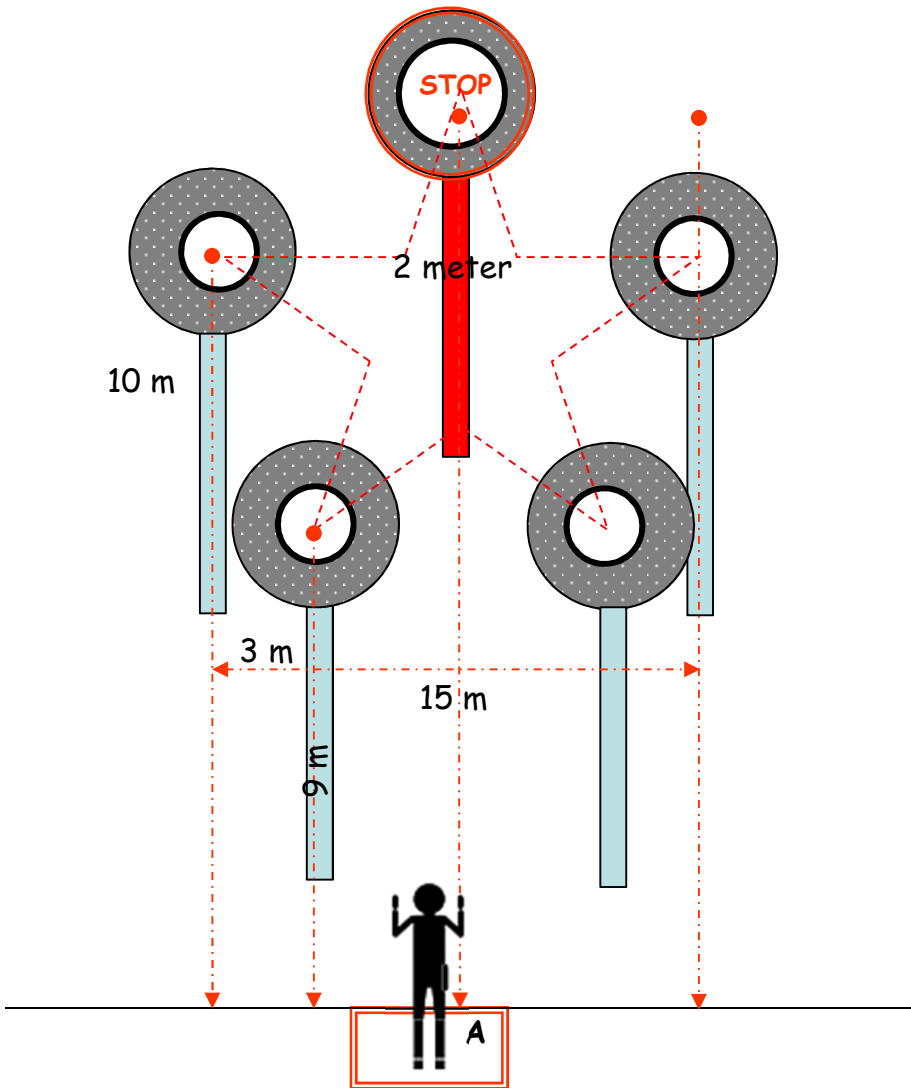

4 x pleet 200
1 x Stoppleet 250

Stage: 5
Shoot "a" Star

Stage: 5 & 6

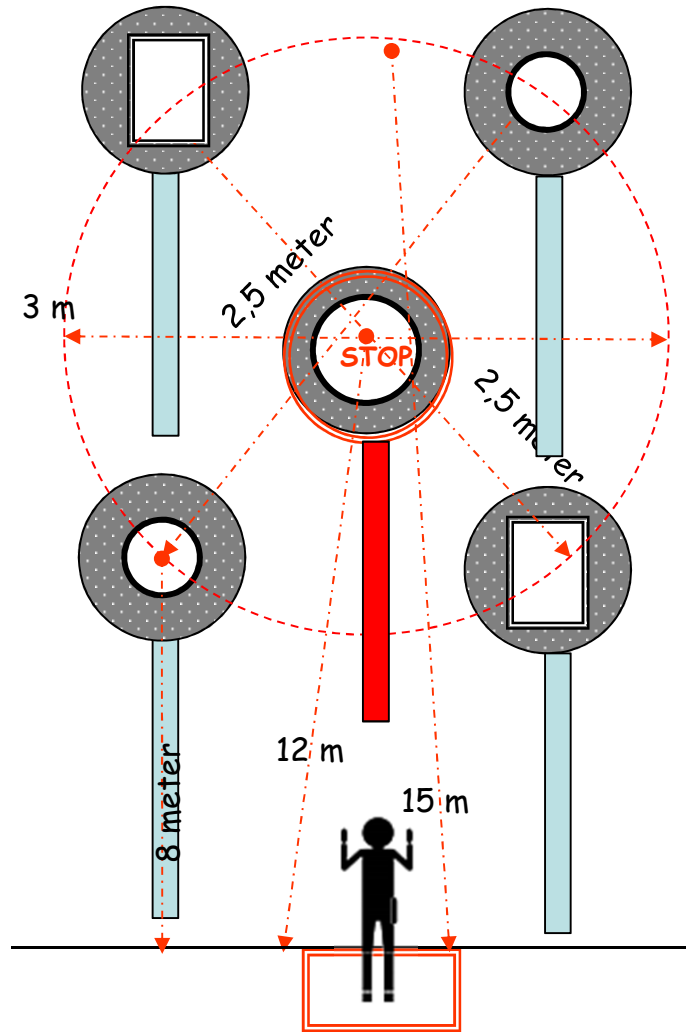

Stage: 6
Five "To" Go

2 x Pleet 150/250
2 x Pleet 200
1 x Stoppleet 250

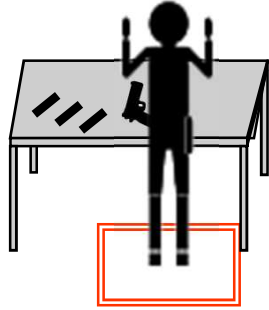
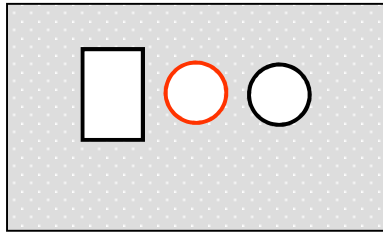

VOLG INSTRUKTIR RO,s

Procedure Niet GEOEFENDE SCHUTTERS

- Wapens blijven in de koffer
- Bij bevel RO, wapen op tafel
- Op bevel "Laden"
- wapen van de tafel nemen
- laden en wapen 45° richting doelen
- Bij start signaal: doorladen en doelen beschieten
- einde stage magazijn verwijderen
- wapen ontladen, onder 45° naar doelen wapen laten controleren of het wapen LEEG is,
- Op bevel RO wapen opbergen in de koffer,

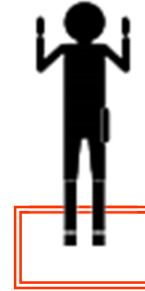
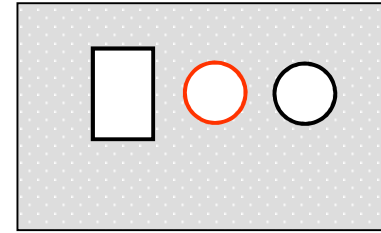

IPSC en of Geoefende Steel shooters

Volg de daarvoor aangegeven procedure van RO

-Wapen doorgeladen in het holster op de bieb wapen trekken en vuren.

Elke Stage wordt 5 x geschoten

-de beste 4 worden geteld

-elke stage bestaat uit 4 + 1 stopplaat(zie stages)